

INSTRUCTIONS DE MONTAGE

IMPORTANT - INSTRUCTIONS À LIRE ATTENTIVEMENT ET À CONSERVER POUR UTILISATION ULTÉRIEURE.

**DES VÉRIFICATIONS DE MONTAGE SONT À EFFECTUER RÉGULIÈREMENT.
À USAGE DOMESTIQUE. NETTOYER À L'EAU CLAIRE.**

DESCRIPTION: BALANCELLE 3 PLACES

RÉFÉRENCE: 10000168739

DIMENSIONS: 180x113 - H155CM

POIDS MAX : 330KG

ATTENTION :

2 personnes sont nécessaires pour assembler la balancelle. Les outils ne sont pas inclus.

Vérifier que toutes les pièces soient présentes dans le carton avant de commencer le montage.

1. Assembler sur une surface plane et lisse.

2. Tenir loin du feu ou de tout objet inflammable.

3. Lors de l'utilisation de la balancelle :

a. Vérifier de bien positionner la balancelle sur une surface plane, lisse et suffisamment solide.

b. Ne pas mettre les bras ou les jambes entre la structure et le siège. Risque de blessure.

c. Ne pas mettre d'objet devant ou derrière la balancelle.

d. Avant toute utilisation, vérifier que la balancelle est bien stable.





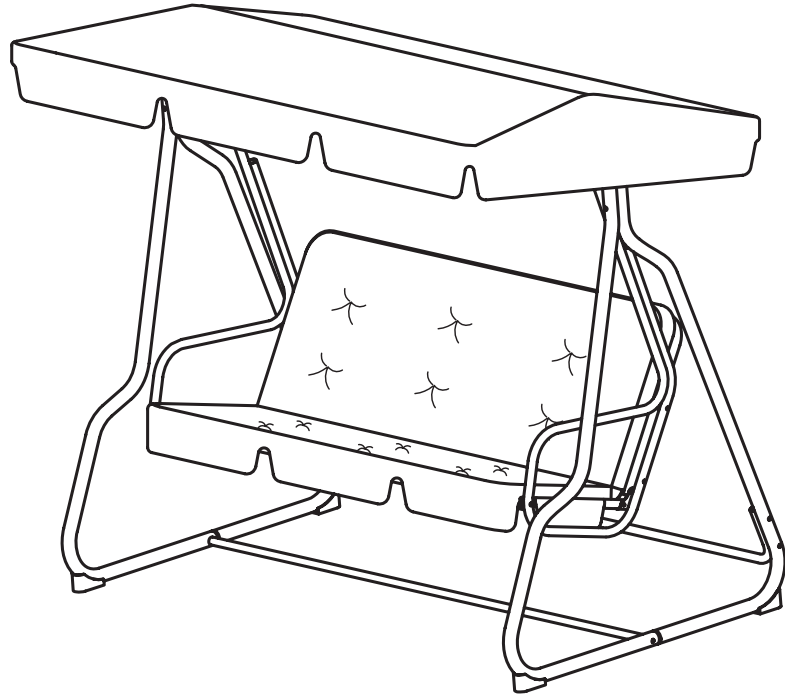

4. Ne pas laisser les enfants utiliser la balancelle sans la surveillance d'un adulte.

5. Au moins une fois par mois, vérifier que toutes les vis et écrous soient bien fixés.

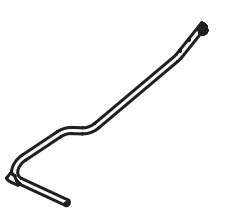
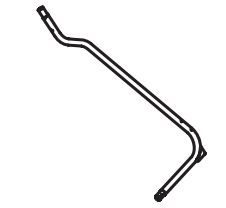
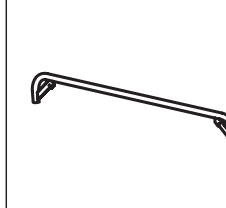
6. Couvrir la balancelle par temps de pluie ou de vent fort.

7. La balancelle n'est pas faite pour résister à l'hiver. La démonter et la ranger dans un endroit sec pendant l'hiver.

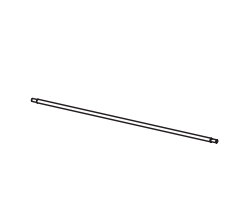
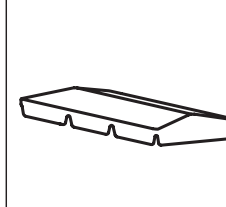
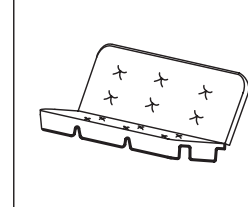
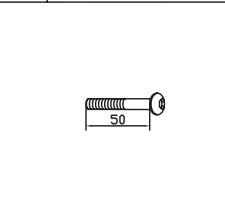
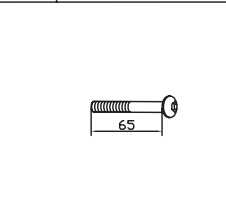
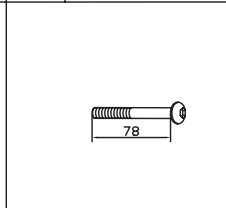
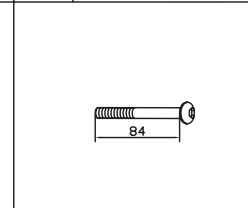
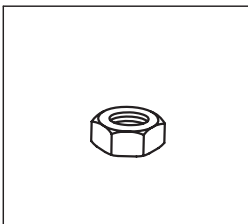
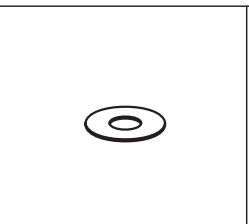
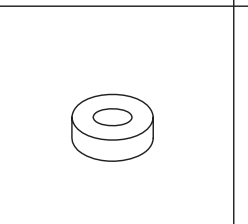
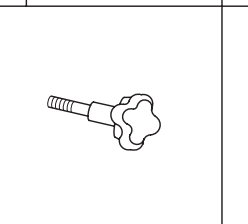
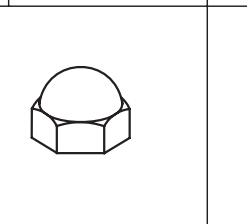
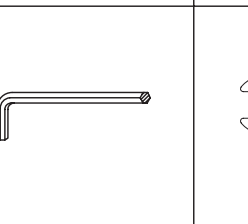
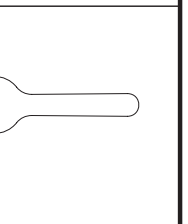

			
A 2	B 2	C 1	E 1
			
F 1	H 2	I 2	J 1
			
K 2	L 2	M 1	N 1
			
O 2	P 4	Q 4	R 4
			
V 12	W 12	X 4	Y 2
			
Z 12	AA 1	BB 1	

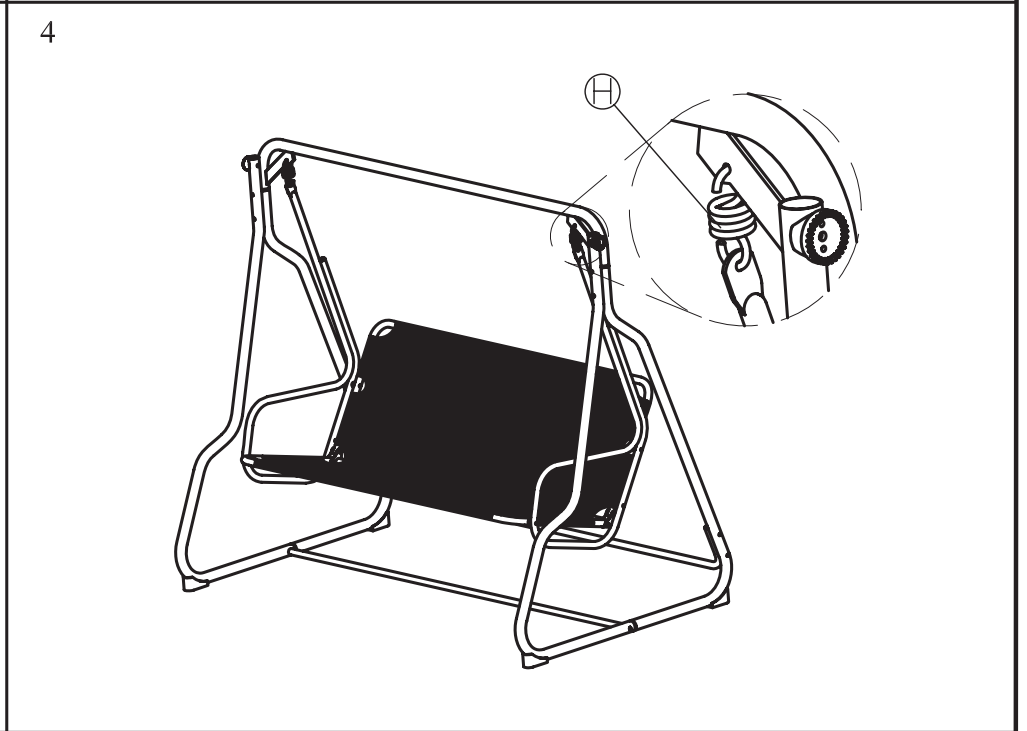
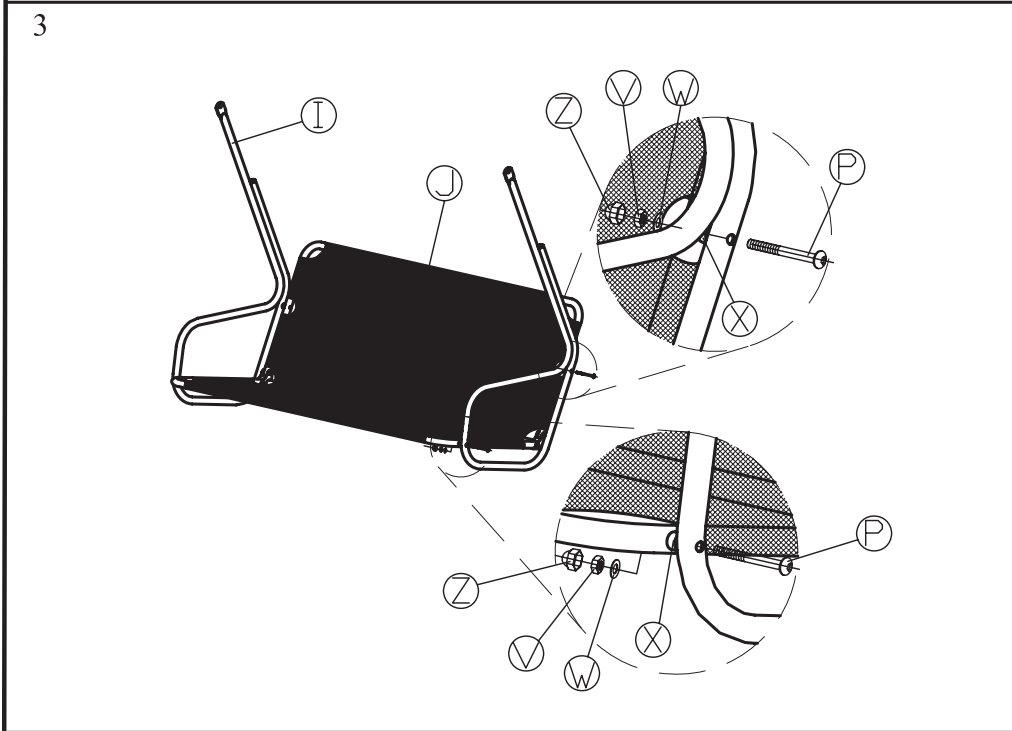
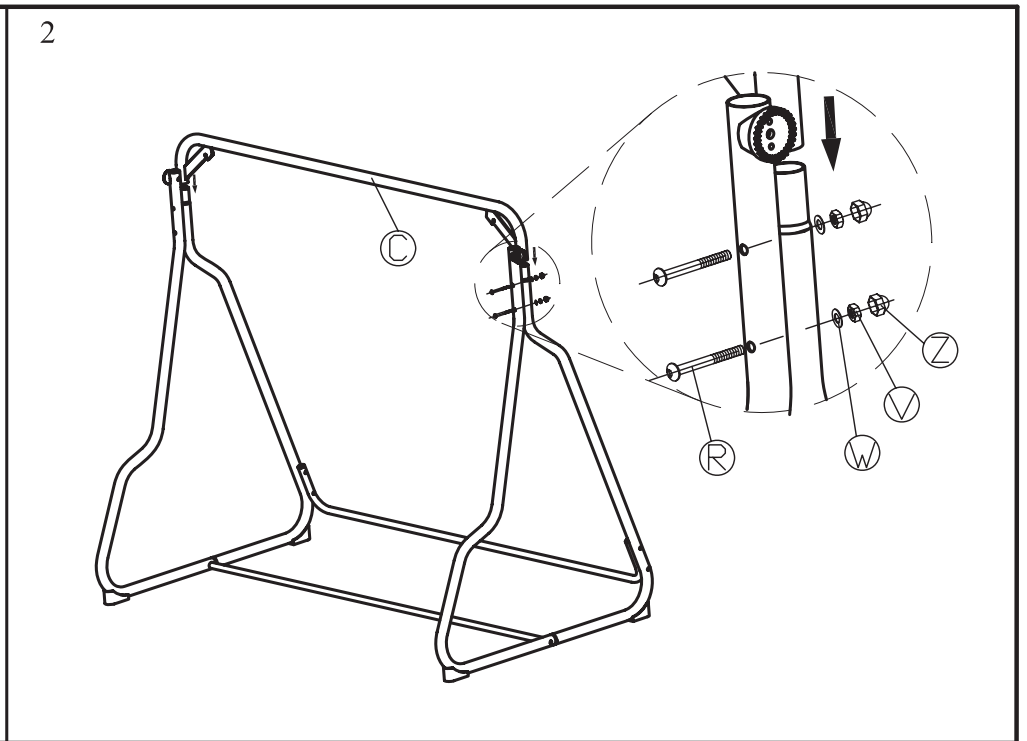
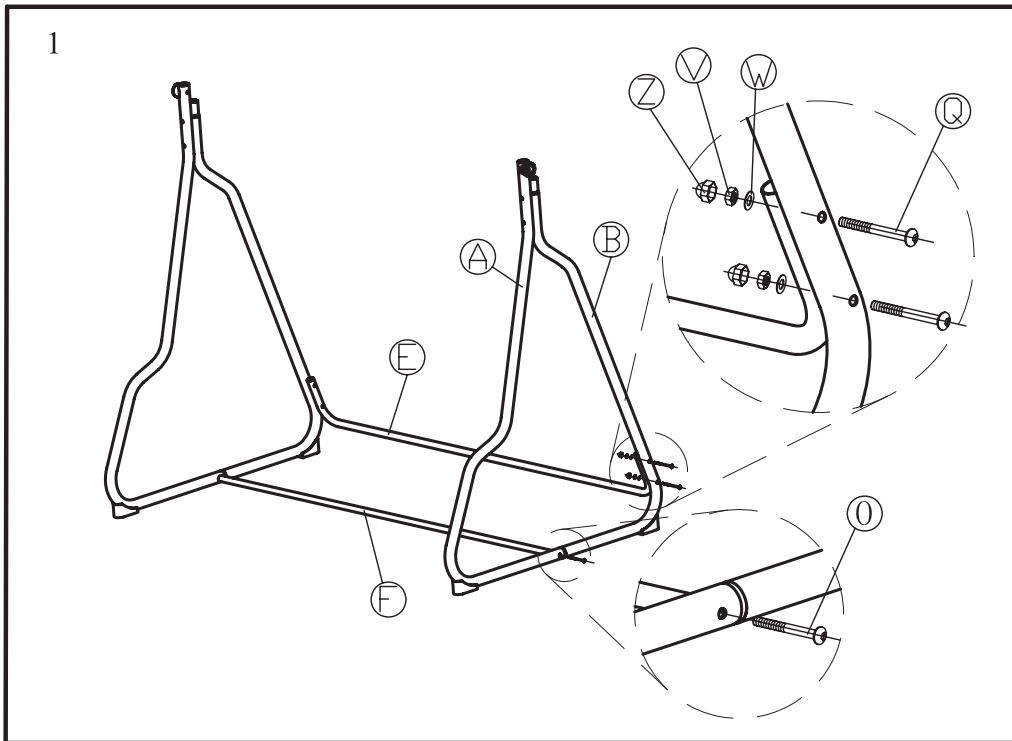

5

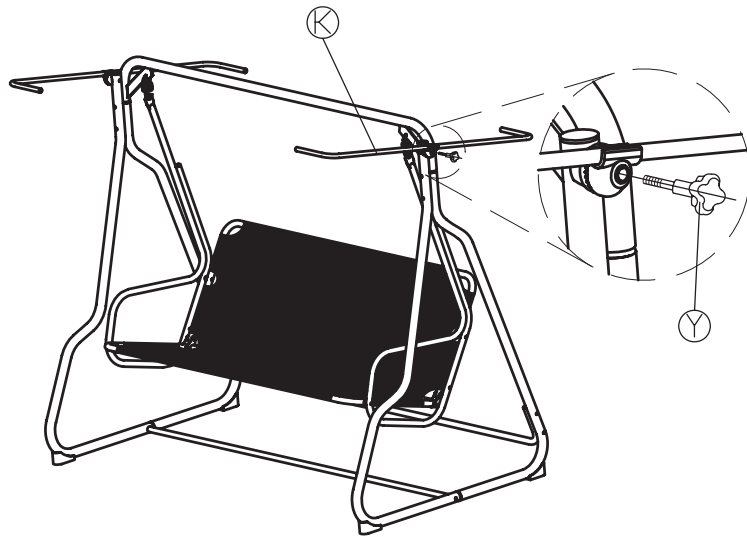

6

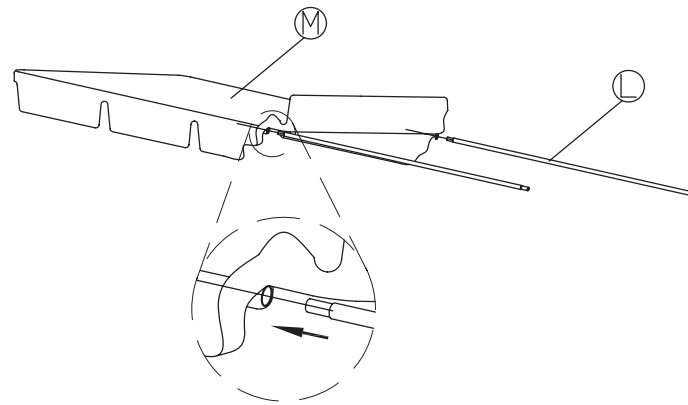

7

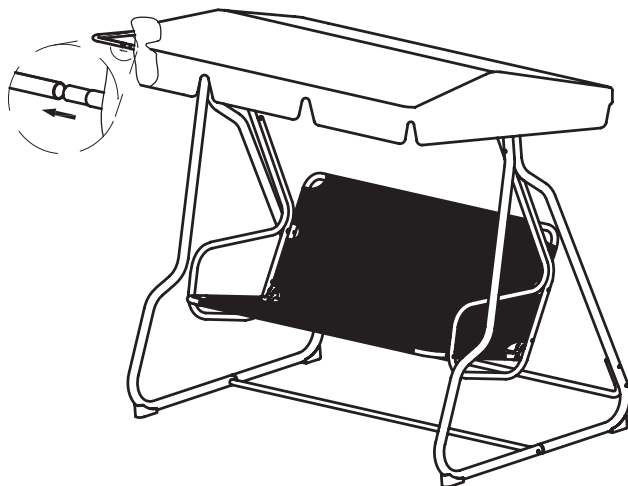

8

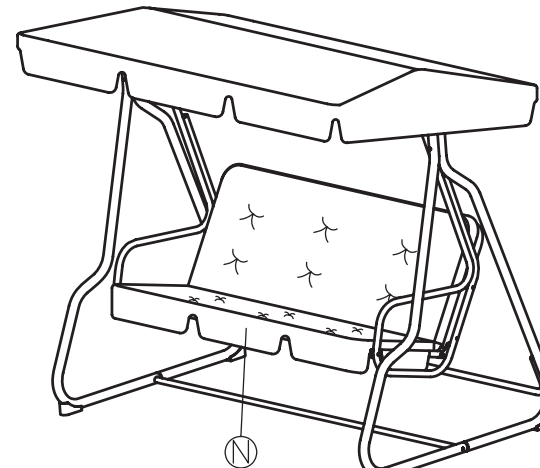

Fabricant :
Hangzhou Mano Leisure Products Co. Ltd
No.1650 Panhuan Road ,
Binjiang District , Hangzhou,Chine
Code postal:310052



À monter soi-même



Fabriqué en Chine
Importé par: La Foir'Fouille S.A.
155 Avenue Clément ADER
34174 Castelnau-le-lez, France